

TYPICAL 40' STREET LAYOUT - CURB TO CURB

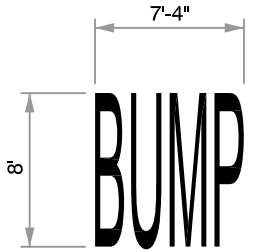

PAVEMENT LEGEND

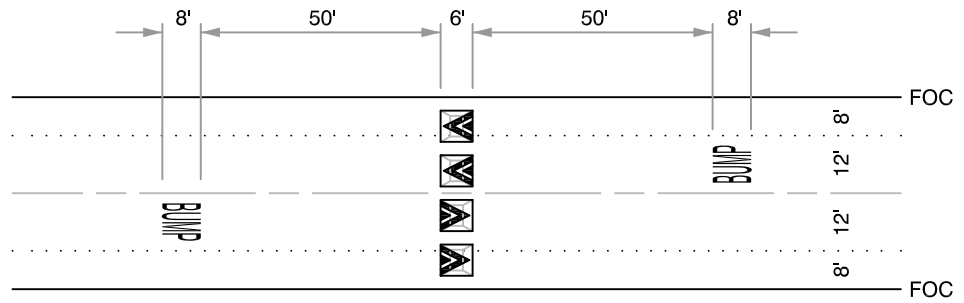

ASPHALT CONCRETE SPEED CUSHION

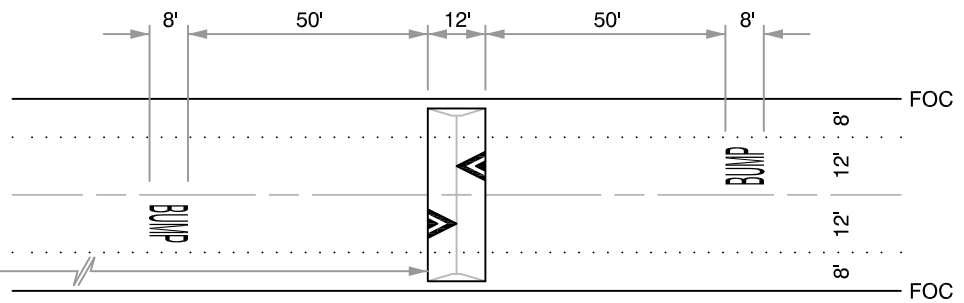

ASPHALT CONCRETE SPEED HUMP



SEE NOTE 2

W17-1, 24"x24"

W13-1, 24"x24"

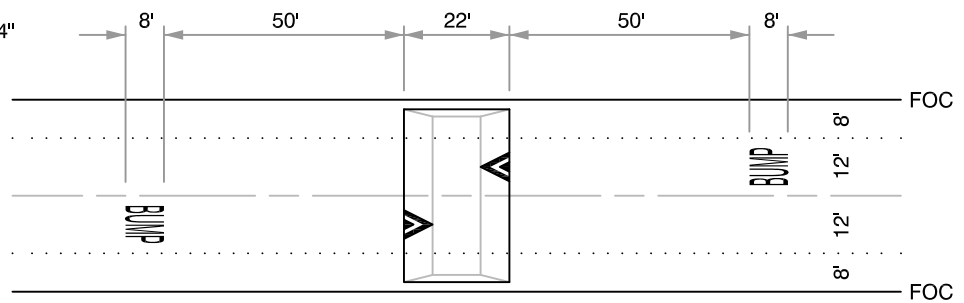

ASPHALT CONCRETE SPEED TABLE

ADVANCE WARNING SIGNS

NOTES:

1. SIGNS AND MARKINGS TYPICAL BOTH DIRECTIONS.
2. DISTANCE TO SIGN 150' OR AS DETERMINED IN THE FIELD BY THE ENGINEER (APPLIES IN ALL THREE CASES).